



**Full Length Article**

# Prediction of Soil Sinkage by Multiple Loadings Using the Finite Element Method

MAJID RASHIDI<sup>1</sup>† AND MOHAMMAD GHOLAMI

†Member of Young Researchers Club, Department of Agricultural Machinery, Faculty of Agriculture, Islamic Azad University, Takestan Branch, Iran

Department of Agricultural Machinery, Faculty of Agriculture, Islamic Azad University, Takestan Branch, Iran

<sup>1</sup>Corresponding author's e-mails: majidrashidi81@yahoo.com; m.rashidi@tiau.ac.ir

## ABSTRACT

It is usual practice to use the same wheel tractor for different agricultural field operations. As the agricultural soil is exposed to multiple loadings of the same magnitude in this situation, it is valuable to predict soil sinkage by multiple loadings so as to utilize the tractor power effectively with minimum compaction effects. For this purpose, the finite element method (FEM) was used to predict soil sinkage by multiple loadings (ten loadings) of a rectangular plate and a two-dimensional FEM program entitled PRESSINK was employed to perform required numerical calculations. The FEM analysis was finally verified through laboratory test. Results of the laboratory test proved that the FEM is a relatively accurate and powerful technique to predict soil sinkage by multiple loadings. Results of the study also indicated that the number of loadings noticeably affected soil sinkage. Moreover, the first three loadings caused critical soil sinkage and the amount of soil sinkage owing to the first three loadings was about 89% and 82% of the total soil sinkage based on the FEM analysis and laboratory test results, respectively. © 2010 Friends Science Publishers

**Key Words:** Finite element method; Soil sinkage; Soil compaction; Multiple loadings; Elastoplastic; Drucker-Prager

## INTRODUCTION

There are many concerns regarding the effects of soil compaction that impedes root growth (Al-Adawi & Reeder, 1996). Soil compaction is a process through, which pore spaces are decreased (Defosseze & Richard, 2002). Soil compaction can be caused by natural phenomena such as rainfall impact, soaking, internal water tension and the like. On the other hand, artificial soil compaction occurs by tractors and agricultural machines (McKyes, 1985). Soil compaction under tractors and agricultural machines is of special concern (Hakansson & Reeder, 1994; Abu-Hamdeh & Reeder, 2003).

The main cause of soil compaction is soil sinkage imposed by wheels or tracks. Therefore, prediction of soil sinkage is incredibly important for determining soil compaction level (Abu-Hamdeh & Reeder, 2003). For the last five decades, prediction of soil sinkage has been of great interest to researchers in both agriculture and cross-country mobility and transport (Bekker, 1956; Reece, 1964; Hegedus, 1965; Kogure, 1983; Upadhyaya, 1989; Upadhyaya *et al.*, 1993; Çakir *et al.*, 1999; Defosseze & Richard, 2002; Rashidi *et al.*, 2005a & b; Rashidi *et al.*, 2006; Rashidi *et al.*, 2007).

Agricultural operations are dependent on wheel tractors as a source of traction power. Also, it is usual practice to use the same tractor for different operations.

Therefore, a significant part of the field is exposed to multiple passes of wheels (Abebe *et al.*, 1989). However, nearly all studies dealing with soil sinkage due to multiple passes of wheels (multiple loadings) have been experimental (Taylor *et al.*, 1982; Koger *et al.*, 1985; Wood & Wells, 1985; Abebe *et al.*, 1989).

Another approach is to utilize finite element method (FEM). The FEM is one of the most powerful techniques for the numerical solution of engineering problems (Hinton & Owen, 1979; Owen & Hinton, 1980; Naylor & Pande, 1981). This method has been also used to solve soil mechanics problems during last 40 years (Rashidi *et al.*, 2005a & b; Rashidi *et al.*, 2007). Moreover, the FEM suggests significant assure for modeling soil mechanical behavior. The FEM is able to model complex loading geometries and the required numerical calculations can be carried out without difficulty on a personal computer. Certainly, latest progresses in improvement of constitutive equations (stress-strain relationships) and theory of plasticity have made the FEM a much more powerful method for modeling soil mechanical behavior. Consequently, the specific objectives of current study were to predict soil sinkage by multiple loadings using the FEM and to evaluate the FEM analysis results using laboratory tests.

## MATERIALS AND METHODS

**Material model development:** In this study, the

elastoplastic material model was used to represent non-linear stress-strain relationship of soil (Naylor & Pande, 1981; Araya & Gao, 1995; Shen & Kushwaha, 1998; Mouazen & Nemenyi, 1999; Abu-Hamdeh & Reeder, 2003; Rashidi *et al.*, 2005a & b; Rashidi *et al.*, 2007).

**Governing equations development:** The governing equations were obtained by using the principle of virtual work (Owen & Hinton, 1980; Shen & Kushwaha, 1998; Rashidi *et al.*, 2005 a & b; Rashidi *et al.*, 2007).

**FEM program development:** A plane-stress, plane-strain and axisymmetric FEM program (PRESSINK) written by Rashidi *et al.* (2005a) was employed to perform required numerical calculations.

**Test unit development:** A test unit was constructed to study soil sinkage by multiple loadings. A self-explanatory schematic picture of the test unit is presented in Fig. 1. The test unit contains a soil bin and a rectangular sinkage plate. The soil bin utilized in the test unit was 250 mm long, 250 mm wide and 250 mm high. Dimensions of the rectangular sinkage plate were 40 mm width and 60 mm length. Note that the aspect ratio (length/width) of the rectangular plate was 1.5, which is similar to the ones expected for the wheel-soil contact areas (for tracks long narrow rectangular sinkage plates are recommended). The aspect ratio of a wheel/track-soil contact area can be defined as the length of the contact area divided by the width of the contact area.

**FEM analysis:** The FEM analysis was based on the assumptions that the wheel-soil contact area can be approximated by a rectangular region and the wheel contact pressure is uniformly distributed over the rectangular region. These assumptions helped to reduce the elaborations of the problem by allowing it to be analyzed as a plane-stress (two-dimensional) problem rather than a three-dimensional problem. Also, the FEM analysis was performed to simulate the same conditions of the soil-rectangular plate system illustrated in the test unit (Fig. 1). In order to predict soil sinkage due to multiple loadings of the rectangular plate, a two-dimensional FEM mesh (Fig. 2) was generated within a rectangle 200 mm long and 125 mm wide. The total number of nodal points and elements were 367 and 108, respectively. The eight-node serendipity elements were chosen as they provide more truthful results for bigger mesh sizes (Fielke, 1999). Because the symmetry about the vertical axis AB, one half of the soil-rectangular plate system was meshed and analyzed. The rectangular plate was assumed to be a rigid body and the loading was distributed uniformly over the top left-side three elements. The soil mechanical properties used for the FEM analysis of soil-rectangular plate system are shown in Table I. Appropriate boundary conditions, initial values and nodal and elemental information were other required data for the FEM analysis. The load application on the FEM model was simulated in an incremental method. For each increment, the displacement of each nodal point was computed. This process was continued until the total pressure of 200 kPa was monotonically applied in increments of 40 kPa. At this

point, the soil was un-loaded in one step to complete the simulation of the first loading and un-loading cycle. Successive loading and un-loading cycles were simulated by reloading and un-loading in one step. Loading and un-loading was done ten times and at the end of each loading and un-loading cycle, the total displacement of each nodal point was obtained.

**Laboratory test:** Laboratory test was performed to verify the prediction of soil sinkage by multiple loadings using the FEM. A sandy-loam soil was chosen for characterizing the agricultural soil. The sandy-loam soil was consisted of 33% sand, 45% silt and 22% clay. To prepare soil bin, as a first step, soil was sieved through a 4-mm mesh sieve. Then, to attain an even soil moisture distribution, the soil was damped and covered with a plastic sheet during the night. The soil moisture content on dry basis was about 18%, which made the soil to be in an arable condition as in the field. The soil was then fitted to the soil bin in five layers of 60 mm and each layer was compacted 20 mm using a wooden packer piston with the aid of a hydraulic press until the soil bin became full up to 200 mm. The soil bulk density of 1.70 g cm<sup>-3</sup> (on wet basis) was determined before multiple loadings tests. Then, for each test run, the rectangular sinkage plate was loaded incrementally up to about 200 kPa in increments of 40 kPa. This process was continued until the total pressure of 200 kPa was applied monotonically (Fig. 3). After that, the soil was un-loaded (Fig. 4) in one step to complete the first loading and un-loading cycle and at the same time the sinkage depth of the rectangular plate was measured using the displacement sensor. Successive reloading (Fig. 5) and un-loading cycles were repeated ten times and at the end of each loading and un-loading cycle, the sinkage depth was measured. Applied loads were measured by HBM-Q3 model load cell and at the same time downwards displacements (soil sinkage values) were measured with HBM-W100 model LVDT (Linear Variable Differential Transducer). Both instruments were connected to an amplifier and to a personal computer equipped with an AD card to amplify and record each test outputs (Fig. 6). Also, multiple loadings test was replicated three times and mean of the measured soil sinkage values was used for statistical analyses.

**Statistical analysis:** A linear regression with zero intercept was carried out to verify the validity of the FEM analysis results. Also, to check the discrepancies between the FEM analysis results and results of the laboratory test, RMSE (root mean squared error) and MRPD (mean relative percentage deviation) were calculated as (Rashidi *et al.*, 2005a & b; Rashidi *et al.*, 2007):

$$RMSE = \sqrt{\frac{\sum_{i=1}^n (z_i - z_i^*)^2}{n}} \quad (1)$$

Where:

$RMSE$  = root mean squared error, mm.

$z_i$  = total soil sinkage due to  $i^{\text{th}}$  loading measured through laboratory test, mm.

$z_i^*$  = total soil sinkage due to  $i^{\text{th}}$  loading predicted using the FEM analysis, mm.

$$MRPD = \frac{100 \times \sum_{i=1}^n \frac{|z_i - z_i^*|}{z_i}}{n} \quad (2)$$

Where:

MRPD = mean relative percentage deviation, %.

## RESULTS AND DISCUSSION

The soil sinkage values under the rectangular plate as related to number of loadings, which were predicted using the FEM analysis are indicated in Fig. 7. The FEM analysis results indicated that the soil sinkage value due to the first loading was larger than the soil sinkage values caused by other loadings. These results also showed that the total soil sinkage owing to the ten loadings was chiefly influenced by the first loading which caused almost 60% of it. Moreover, second and third loadings caused nearly 22% and 7% of the total soil sinkage, respectively. Based on the FEM analysis results, the first three loadings were critical and the amount of soil sinkage due to the first three loadings was about 89% of the total soil sinkage. According to the FEM analysis results, remaining loadings i.e., fourth to tenth loadings altogether caused only 11% of the total soil sinkage.

The soil sinkage values under the rectangular plate as related to number of loadings, which were measured using through the laboratory test are also demonstrated in Fig. 7. Results of the laboratory test confirmed that the soil sinkage value owing to the first loading was larger than the soil sinkage values caused by other loadings. These results also proved that the total soil sinkage due to the ten loadings was chiefly influenced by the first loading, which caused approximately 57% of it. Furthermore, second and third loadings caused just about 19 and 6% of the total soil sinkage, respectively. Based on the laboratory test results, the first three loadings were critical too and the amount of soil sinkage due to the first three loadings was about 82% of the total soil sinkage. Based on the laboratory test results, remaining loadings i.e., fourth to tenth loadings in total caused only 18% of the total soil sinkage.

By comparing two curves, it was concluded that the FEM analysis and the laboratory test gave identical results. To verify the validity of the FEM analysis results a linear regression with zero intercept was carried out. The soil sinkage values under the rectangular plate as related to number of loadings predicted using the FEM analysis and those measured through the laboratory test were plotted against each other and fitted with a linear equation with zero intercept (Fig. 8). The slope of the line of best fit and its co-

Fig. 1: Test unit

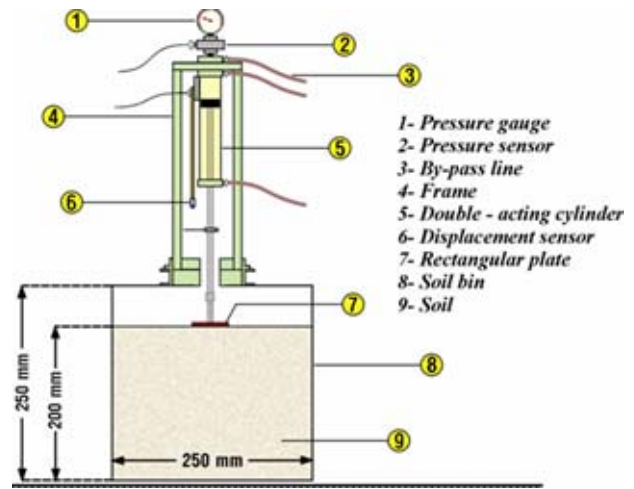
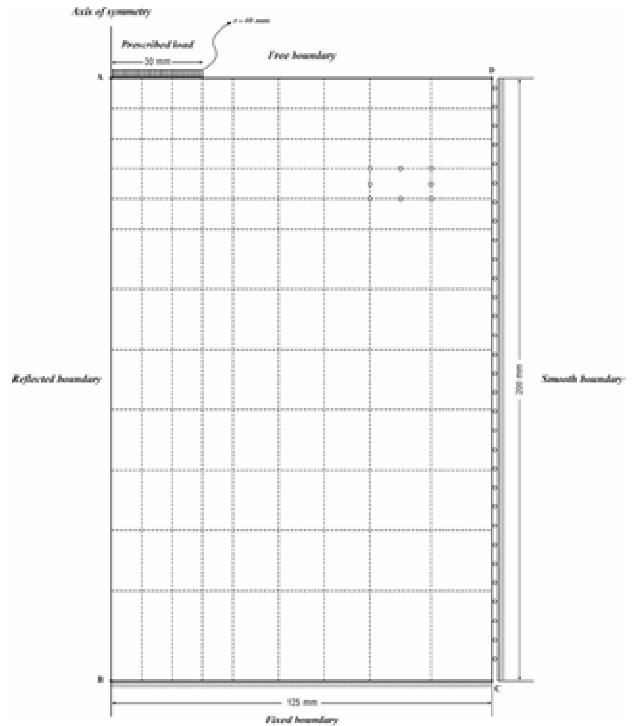

Fig. 2: Two-dimensional FEM mesh of the soil-rectangular plate system



efficient of determination ( $R^2$ ) were 0.9032 and 0.9942, respectively. Moreover, to check the discrepancies between the FEM analysis results and results of the laboratory test, RMSE and MRPD were calculated. The amounts of RMSE and MRPD were 9.6 mm and 11.1%, respectively.

Such negligible discrepancies between the FEM analysis results and results of the laboratory test probably stem from precision modeling of soil behavior. These results are in line with those of Mouazen and Nemenyi (1999) and Abu-Hamdeh and Reeder (2003), who concluded that both material and geometrical non-linearity

Fig. 3: Loading process

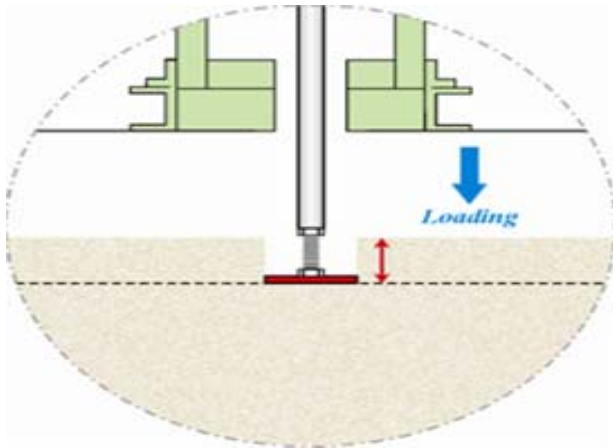

Fig. 4: Unloading process

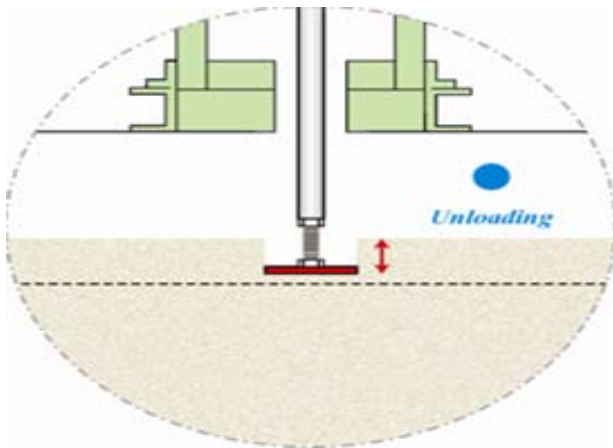
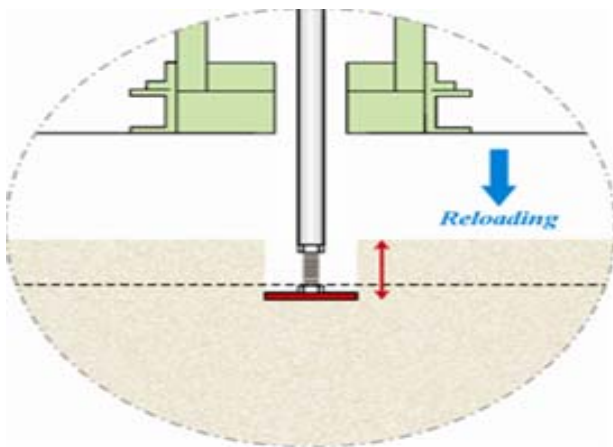

Fig. 5: Reloading process



govern soil deformations. These results are also in agreement with those of Rashidi *et al.* (2005a & b) and Rashidi *et al.* (2007), who concluded that to correctly predict soil mechanical behavior, material and geometrical non-linearity should be accounted.

Fig. 6: Data acquisition system

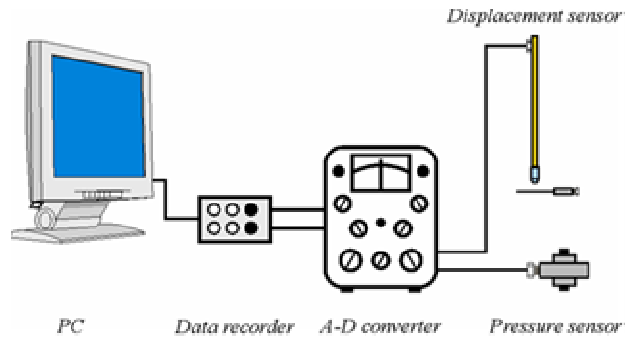

Fig. 7: Soil sinkage values under the rectangular plate as related to number of loadings predicted using the FEM analysis in compared with those measured through the laboratory test

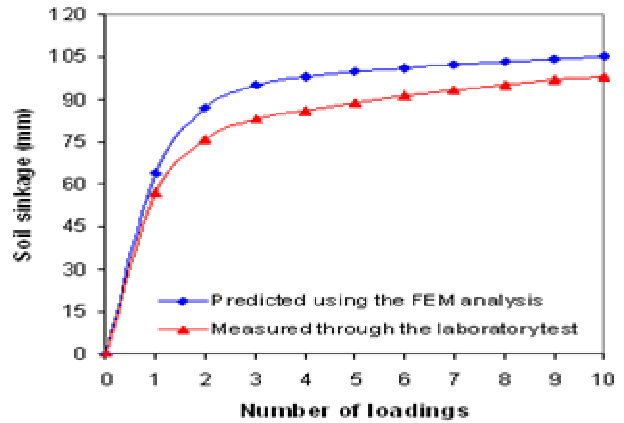
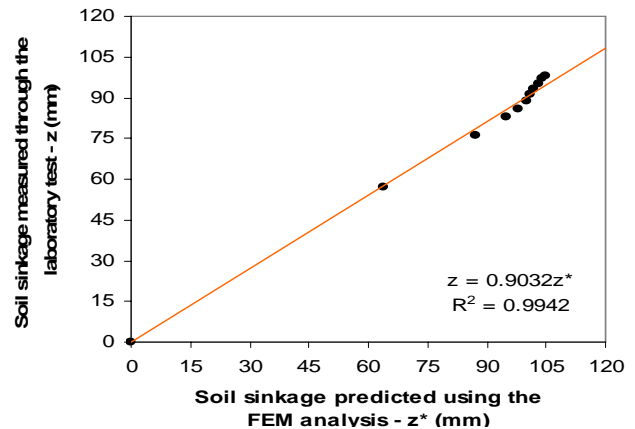

Fig. 8: Soil sinkage values predicted using the FEM analysis and soil sinkage values measured through the laboratory test are plotted against each other and fitted with a linear equation with zero intercept



## CONCLUSION

Prediction of soil sinkage by multiple loadings using the FEM analysis and evaluation of the FEM analysis results through laboratory test proved that the FEM is a

**Table I: Soil mechanical properties used for the FEM analysis of the soil-rectangular plate system**

Soil mechanical property	Symbol	Unit	Amount
Modulus of elasticity	E	MPa	150
Poisson's ratio	$\nu$	---	0.3
Cohesion	c	kPa	80
Angle of internal friction	$\phi$	deg	30

relatively accurate and powerful technique to predict soil sinkage by multiple loadings. Also, the first three loadings caused critical soil sinkage and the amount of soil sinkage due to the first three loadings was about 89% and 82% of the total soil sinkage based on the FEM analysis and laboratory test results, respectively.

**Acknowledgment:** The authors are very much grateful to the Islamic Azad University, Takestan Branch, Iran for giving all types of support in conducting this study.

## REFERENCES

- Abebe, A.T., T. Tanaka and M. Yamazaki, 1989. Soil compaction by multiple passes of a rigid wheel relevant for optimization of traffic. *J. Terramech.*, 26: 139–148
- Abu-Hamdeh, N.H. and R.C. Reeder, 2003. Measuring and predicting stress distribution under tractive devices in un-disturbed soil. *Biosys. Eng.*, 85: 493–502
- Al-Adawi, S.S. and R.C. Reeder, 1996. Compaction and subsoiling effects on corn and soybean yields and soil physical properties. *Trans. ASAE*, 39: 1641–1649
- Araya, K. and R. Gao, 1995. A non-linear three-dimensional finite element analysis of subsoiler cutting with pressurized air injection. *J. Agric. Eng. Res.*, 61: 115–128
- Bekker, M.G., 1956. *Theory of Land Locomotion-the Mechanics of Vehicle Mobility*, p: 522. University of Michigan Press, Ann Arbor, Michigan
- Çakir, E., E. Gülsoylu and G. Keçecioglu, 1999. Multiplate penetration tests to determine soil stiffness moduli of Ege region. In: *Proceedings of International Congress on Agricultural Mechanization and Energy*. 26-27 May, 1999, Adana-Turkey
- Defosse, P. and G. Richard, 2002. Models of soil compaction due to traffic and their evaluation. *Soil Till. Res.*, 67: 41–64
- Fielke, J.M., 1999. Finite element modeling of the interaction of the cutting edge of tillage implements with soil. *J. Agric. Eng. Res.*, 74: 91–101
- Hakansson, I. and R.C. Reeder, 1994. Subsoil compaction by vehicles with high axle load-extent, persistence and crop response. *Soil Till. Res.*, 29: 277–304
- Hegedus, E., 1965. Plate sinkage study by means of dimensional analysis. *J. Terramech.*, 2: 25–32
- Hinton, E. and D.R.J. Owen, 1979. *An Introduction to Finite Element Computation*. Swansea, Pineridge Press Limited, UK
- Koger, J.L., E.C. Burt and A.C. Trowse, 1985. Multiple pass effects of skidder tires on soil compaction. *Trans. ASAE*, 28: 11–16
- Kogure, K., Y. Ohira and H. Yamaguchi, 1983. Prediction of sinkage and motion resistance of a tracked vehicle using plate penetration test. *J. Terramech.*, 20: 121–128
- McKyes, E., 1985. *Soil Cutting and Tillage*. Elsevier Science Publishing Company Inc., New York, USA
- Mouazen, A.M. and M. Nemenyi, 1999. Finite element analysis of subsoiler cutting in non-homogeneous sandy loam soil. *Soil Till. Res.*, 51: 1–15
- Naylor, D.J. and G.N. Pande, 1981. *Finite Elements in Geotechnical Engineering*. Pineridge Press, Swansea, UK
- Owen, D.R.J. and E. Hinton, 1980. *Finite Elements in Plasticity, Theory and Practice*. Pineridge Press, Swansea, UK
- Rashidi, M., R. Attarnejad, A. Tabatabaefar and A. Keyhani, 2005a. Prediction of soil pressure-sinkage behavior using the finite element method. *Int. J. Agric. Biol.*, 7: 460–466
- Rashidi, M., A. Tabatabaefar, R. Attarnejad and A. Keyhani, 2005b. Non-linear modeling of soil pressure-sinkage behavior applying the finite element method. In: *Proc. Int. Agric. Engin. Conf.* 6-9 December, 2005 Bangkok, Thailand
- Rashidi, M., A. Keyhani and A. Tabatabaefar, 2006. Multiplate penetration tests to predict soil pressure-sinkage behavior under rectangular region. *Int. J. Agric. Biol.*, 8: 5–9
- Rashidi, M., A. Tabatabaefar, R. Attarnejad and A. Keyhani, 2007. Non-linear modeling of pressure-sinkage behavior in soils using the finite element method. *J. Agric. Sci. Technol.*, 9: 1–13
- Reece, A.R., 1964. *Problems of Soil-Vehicle Mechanics, Land Locomotion Laboratory Report No. 8470 (LL97)*. Warren, Mich., US Army Tank-Automotive Center
- Shen, J. and R.L. Kushwaha, 1998. *Soil-Machine Interaction, A Finite Element Perspective*. Marcel Dekker, Inc. New York
- Taylor, J.H., A.C. Trowse, E.C. Burt and A.C. Bailey, 1982. Multipass behavior of a pneumatic tire in tilled soil. *Trans. ASAE*, 25: 1229–1236
- Upadhyaya, S.K., 1989. *Development of a Portable Instrument to Measure Soil Properties Relevant to Traction*. Research report, Davis, California, Agricultural Engineering Department, University of California
- Upadhyaya, S.K., D. Wulfsohn and J. Mehlschau, 1993. An instrumented device to obtain traction related parameters. *J. Terramech.*, 30: 1–20
- Wood, R.K. and L.G. Wells, 1985. Characterizing soil deformation by direct measurement within the profile. *Trans. ASAE*, 28: 1754–1758

(Received 29 April 2010; Accepted 18 May 2010)